



City of Rancho Palos Verdes  
Building & Safety Division  
(310) 265-7800

[www.palosverdes.com/rpv](http://www.palosverdes.com/rpv)

**You Can Strengthen  
Your Home For  
The Next Big Earthquake  
In The City Of Rancho Palos Verdes**



**Easy, low ~ cost ways to  
Help reduce the risk of  
Damage to your home**

Can help you to  
make your home  
more secure in our  
next earthquake



## Common Construction Problems In R P V Neighborhoods

Many of the older homes in Rancho Palos Verdes were built using older construction techniques which are inadequate for the forces we now know earthquakes can cause; but, these older homes can be reinforced easily and inexpensively.

### Older Homes Are Typical Victims...

Homes built prior to 1940 in Rancho Palos Verdes were built without being bolted to their foundations. Without this anchorage, a large earthquake can move the ground and the foundation right out from under the house. Older homes were damaged or destroyed in this manner by every major earthquake in California's history.

### ...But Earthquakes can Cripple Modern, Anchored Homes, Too

Some wood frame homes built as recently as the 1970's were shaken off their foundation in recent earthquakes. Even though these modern homes were bolted down, they failed because of weak bracing materials on the cripple walls. A cripple wall is a short wall that connects the foundation to the first floor of the house and encloses the "crawl space." Weak bracing materials, like cement plaster (stucco) or wood siding, are likely not strong enough to survive the force of moderate to strong earthquakes. The cripple wall must be braced with stronger materials like plywood. If not, the next earthquake may damage the cripple wall and move your home off its foundation, even if you've bolted it down.

### Conduct Your Own Survey What to Look For

To check your home's earthquake fitness, all you need is a flashlight and a willingness to get a little bit dirty. The place to start is in the crawl space underneath your home.

# 1 Is your House Properly Bolted Down to its foundation?

The wood that rests directly on the foundation is called a mud sill. Until the 1940's, home builders often did not bolt the mud sill to the foundation. This creates a serious structural weakness that can allow your home to slide off its foundation during an earthquake. The mud sill should be bolted at four to six-foot intervals and within one foot of every joint, but no closer than nine inches to the end of the board.

# 2 Do You Need Plywood on Your Cripple Wall?

Check to see if you have a cripple wall and if it is braced with plywood. If the cripple wall is covered on the exterior with only stucco or wood siding, it is not strong enough to resist earthquakes. You will likely need to add plywood. See page 9 for more information about cripple walls on Standard Plans.

# 3 Check for Faulty Materials in the Concrete and the Wood Framing.

The foundation is a common area of structural weakness. When concrete foundations are porous or crumbly, they will not provide adequate strength to resist earthquakes. Unreinforced brick or stone masonry may need to be replaced or strengthened. An engineer or architect is required to design these types of repairs. Check to see if there is insect damage or dry rot in the wood. You will need to replace or repair any faulty wood before you can proceed.

## Bolting your mud sill to the foundation and adding plywood to the cripple

walls are the two most cost – effective steps you can take to strengthen your home for earthquakes.

**Bolts** secure your homes mud sill to the concrete foundation. The mud sill should be anchored as specified on Standard Plans

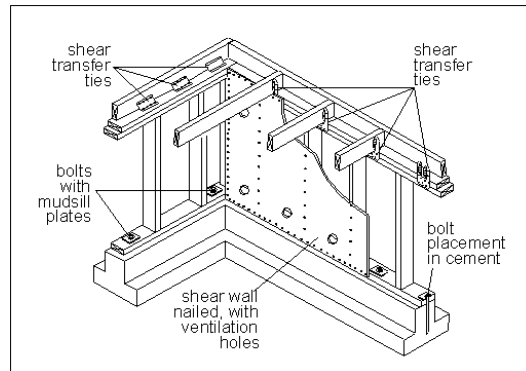

**Sheets of Plywood** nailed to the cripple walls help to prevent damage from shaking in this weak area of your house. Cross-bracing within the framing is not enough.

**Faulty materials** such as rotten wood and porous concrete should be replaced. Risky conditions in concrete include cracks wider than 1/8th inch, large voids, or “honeycomb” concrete. If the concrete chips or flakes when you poke it with a screwdriver, it may need to be replaced. **NOTE:** If you suspect faulty material, you may need the assistance of a licensed engineer or architect to design a solution.

# HOW TO BOLT YOUR HOME TO YOUR FOUNDATION

The first step to take if you find your home does not have anchor bolts, or has too few, is to install them! Because anchor bolts cost as little as \$2 each, the perimeter of the average size home can be bolted down by the do-it yourselfer for a couple of hundred dollars. To install them, follow the procedure below and on Standard Plans.

## 1 Measure and Mark

Mark the places for each bolt on the mud sill. Make the first mark between nine and twelve inches from the end of any piece of mud sill and then mark every six feet for one-story and every four feet for two or three-story homes. Continue this pattern along all of the exterior foundation walls. Make sure you mark each end of the mud sill at stepped foundations. See page 6 for a stepped foundation.

**\$200 in bolts can prevent many thousand of dollars of earthquake damage**

### CHECKLIST

- ✓ 1/2" or 5/8" diameter anchors with nuts and square plate washers
- ✓ Rotary hammer drill with a 1/2" or 5/8" by 9" carbide tip drill bit (Available from rental yards)
- ✓ Adjustable wrench
- ✓ Measuring tape
- ✓ Torque wrench
- ✓ Dust mask and goggles
- ✓ Short-handled sledge hammer for setting expansion bolts
- ✓ Respirator, air blower and nylon brush for adhesive anchors

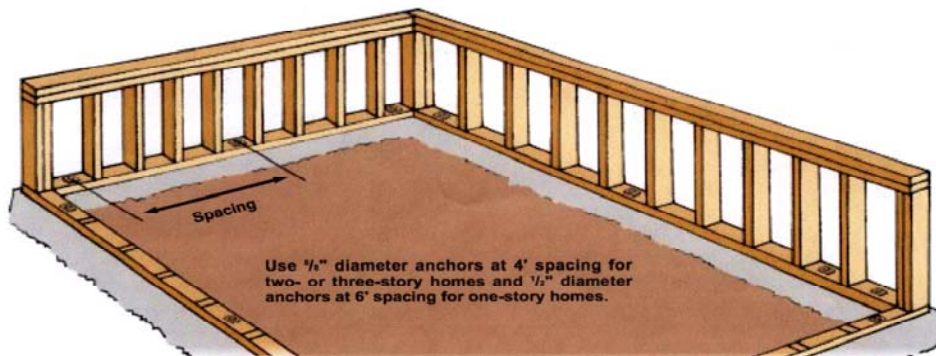
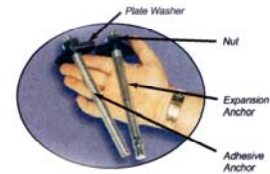

## 2 Drill the Holes

Use the drill bit diameter specified by the anchor manufacturer. The hole in the concrete will be the same diameter as the anchor for the expansion anchor and slightly larger for the adhesive anchor. When you can easily drill the hole in the concrete, the concrete strength is low. The hole must be deep enough to exceed the minimum depth approved for the anchor. If you drill the holes seven inches deep for the expansion anchors they will be deep enough.



## 3 Clean the Holes

Follow the manufacturer's instructions on how to clean out the hole. Holes for adhesive anchors need careful cleaning. Some products require water cleaning and others use only a blower and nylon brush. Holes for expansion anchors do not need to be cleaned if they can be drilled deeper than required. This allows the drilling dust to settle out of the way.

## 4 Install The Anchors

### Expansion Anchors

Place the plate washer on the anchor and then thread the nut on the anchor. Place this anchor assembly into the hole and hammer on the nut to drive the anchor into the hole. Hammer the anchor down until the nut stops at the plate washer on top of the mud sill. Now tighten the nut down on the plate washer to connect your mud sill to the foundation. When you tighten the nut on an installed expansion anchor, the anchor's other end expands to grip the concrete. You will feel it "grab" the foundation as you tighten the nut. If the concrete breaks during tightening of the expansion anchor, the concrete strength is low and you will need to use an adhesive anchor. When your concrete has enough strength, the expansion anchor is easier and cheaper to install than the adhesive anchor.

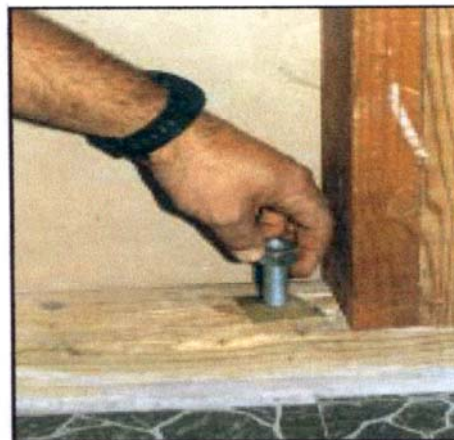

### Adhesive Anchors

Adhesive anchors require more care but are as strong as expansion anchors. Follow the manufacturer's directions on how to clean the drilled hole and how to mix and place the chemical. Always use a fully threaded rod in the hole. Check for the hardening time and after the chemical has set, tighten the nut firmly with a wrench.

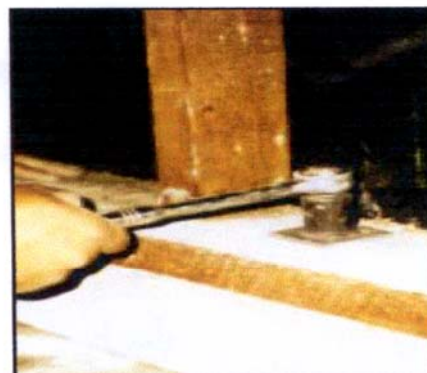

## Stepped Foundation

If your house is built on a hill or even a slight grade, you probably have some step-like offsets in your foundation. On every step, the mud sill must be bolted down at each end and along its length.

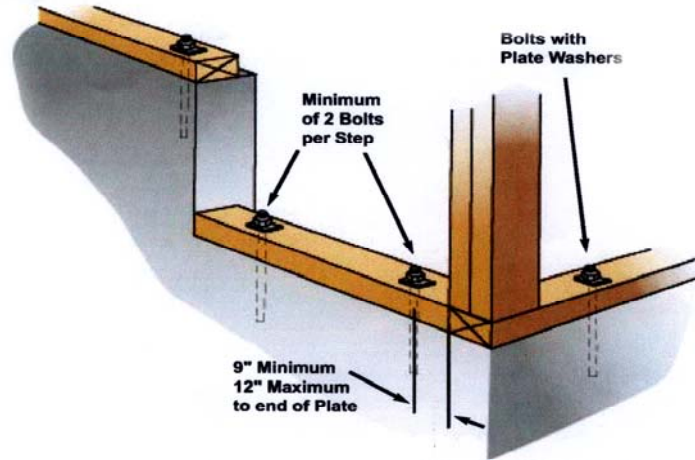

**Caution:** An engineer or architect must prepare the construction plans for the strengthening of homes built on hills steeper than three foot horizontal to one foot vertical.

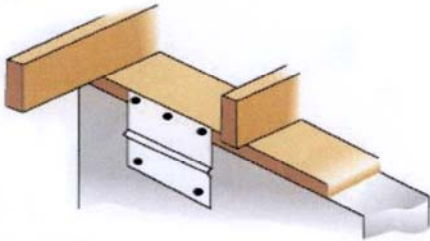

## Retrofit Foundation Plates

Some floors are supported directly on the foundation without cripple walls. This makes anchoring the mud sill difficult because of the lack of drilling space. Plates can be used to attach to the side of the mud sill with wood screws and anchor to the concrete with either expansion or adhesive anchors.

The mud sill must be pre-drilled before the lag or wood screws can be installed. This helps prevent splitting of the wood. The Standard plans have more information on proper installation methods. Be sure to use the type and length of screw recommended by the plate manufacturer.

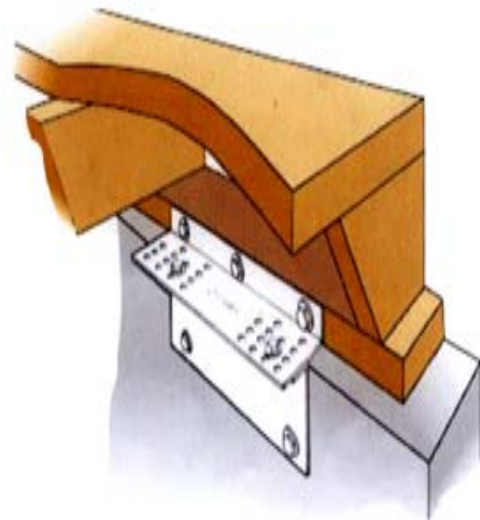

# How To Strengthen Your Wood Walls

## 1 Plywood

Figure out how much plywood you will need on each cripple wall and where it should be placed. Plywood coverage is based on the number of stories. Plywood wall bracing is required at each wall end and for 50 percent of the length for one-story homes, 70 percent for two-story homes, and 100 percent for three-story homes. Use sheets at least four feet in length and no shorter than twice the height of the cripple wall. An easy way to distribute the plywood is to put one-third of the required length on each wall end and the remaining one-third at the center of the wall.

For example, if you have a single-story home with 48 feet of cripple wall on one side, at least 24 feet of plywood is required for that side. You can put two eight-foot sheets of plywood on each end and one eight-foot sheet near the middle of the wall. Or you can use six four-foot sheets evenly distributed along the wall with one panel at each end. This second alternative will allow you to avoid any piping, chimneys or ventilation holes at the cripple wall.

### CHECKLIST

- ✓ ½" CDX five-ply plywood (do not use "shop-grade" plywood)
- ✓ 8-penny, 10-penny and 16-penny common nails
- ✓ Drill
- ✓ Saw
- ✓ Hammer
- ✓ Nail Gun
- ✓ Measuring Tape
- ✓ Chalk Line
- ✓ Dust mask and protection for eyes and ears
- ✓ Blocking lumber
- ✓ Framing anchors

### Bolts are Not Enough

Even when your house is bolted to its foundation, the sideways (lateral) force of an earthquake can make the weakest part of your house (typically the cripple walls) buckle and collapse. Plywood sheets should be nailed to the cripple walls on all sides of your house. These sheets create "shear panels" that give the house "lateral strength." Old-fashioned 2x4 or 2x6 cross-braces and horizontal braces are not strong enough during a strong earthquake.

## 2 Blocking

Frequently lumber has to be added in the crawlspace for the new wall bracing or to attach the floor to the cripple wall. These lumber pieces are called blocking. They provide nailing surfaces for the plywood and framing anchors connect the floor to the cripple wall or mud sill. See examples of blocking in the drawing on page 8.

Cripple walls are usually built with studs that are four inches wide. The mud sill is usually six inches wide. This difference in width requires blocking to be added to the top of the mud sill. The blocking provides a nailing surface for the plywood at the bottom of the sheet.

Some floor members sit on top of mud sills or cripple walls with out blocking between them. The lack of blocking can cause the floor members to fall over sideways in an earthquake. It also makes it difficult to connect the floor to the cripple wall or mud sill. If the blocking is missing between the floor members, it must added to help put the earthquake forces into the strengthened wall.

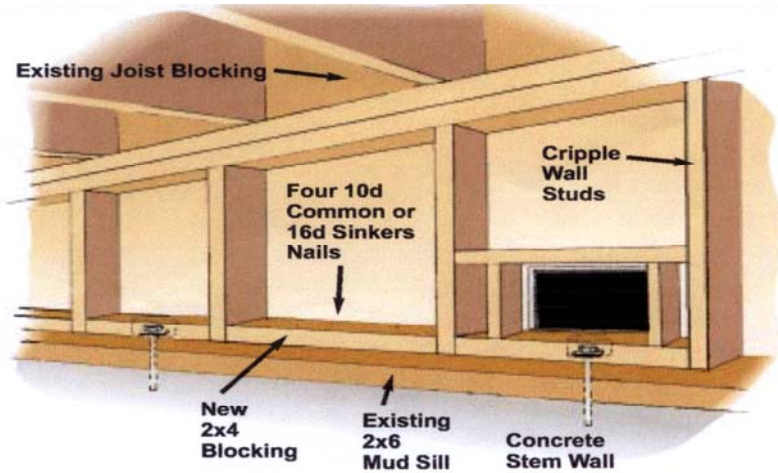

### 3 Framing Anchors

Framing anchors are small sheet metal connectors used to fasten wood members together. They are used to connect your floor framing to newly strengthened foundation or cripple wall. Although the existing floor is connected with nails, these nails tend to rust and loosen over time. The nails are also driven at an angle which is not as strong as nails driven straight in the framing anchors. The addition of framing anchors helps to make sure the building is properly connected to the newly strengthened part.

Framing anchors are four-and-one-half inches long and use twelve 8d nails. They may be attached at the top of the cripple wall or to newly added blocking. Framing anchors are not directly attached to the floor members.

### 4 Nailing

Nailing into old wood can cause splitting. Sometimes you will need to pre-drill holes when nailing the added blocking. If you blunt the end of the 10d or 16d nails before you drive them, they will be less likely to split the wood. Plywood nailing is usually done by contractors with nail guns to speed up the work, but it can be done by hand. Sometimes small working areas make hand nailing difficult.

Most of the strength of the wall bracing comes from the nailing of the plywood. Make sure you use 8d common nails with full heads on them. Place the nails at four-inch spacing along all edges of the plywood sheets. The middle of the sheets can be nailed every twelve inches into the studs.

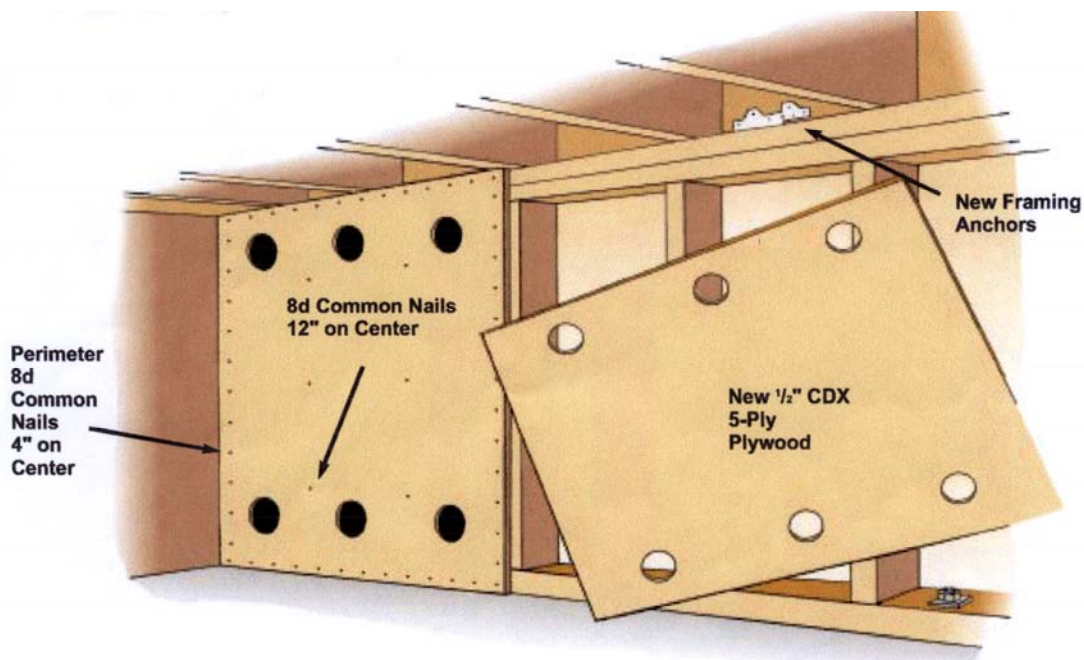

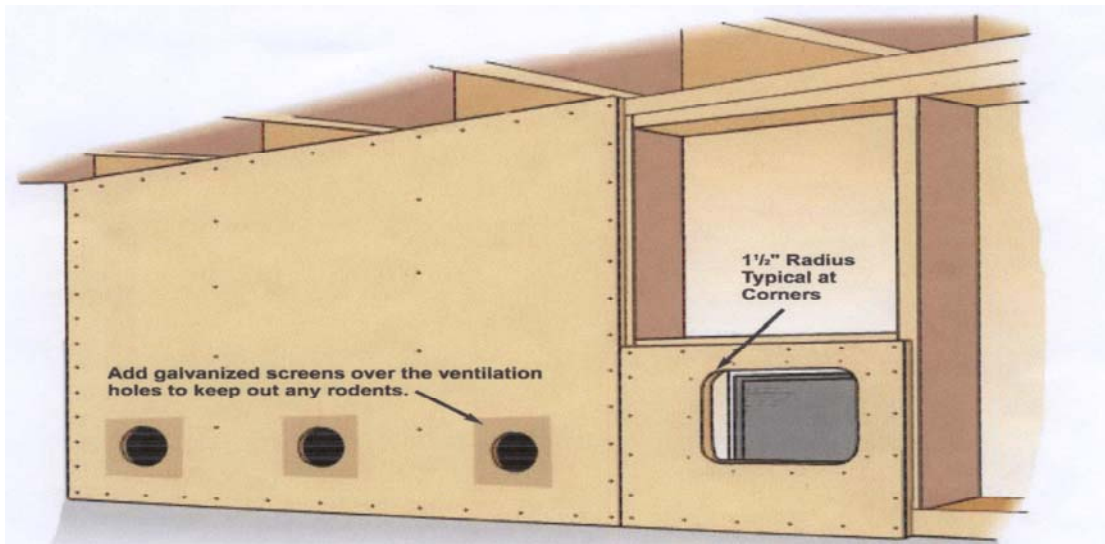

## 5 Ventilation Holes

With the plywood in place, drill two to three-inch ventilation holes in each sheet. These holes should be centered above any anchor bolts, between each set of studs, and one inch above the mud sill and two-and-one-half inches below the bottom of the plate. The holes will provide ventilation and allow inspection of the cripple wall. Drill only one hole if the plywood sheet is less than 18 inches tall. If your wall has an exterior ventilation screen, you should cut a hole in the plywood opposite the screen and similar to it in size. Don't forget to add blocking around this vent hole and hole and nail the plywood edges four inches on center.

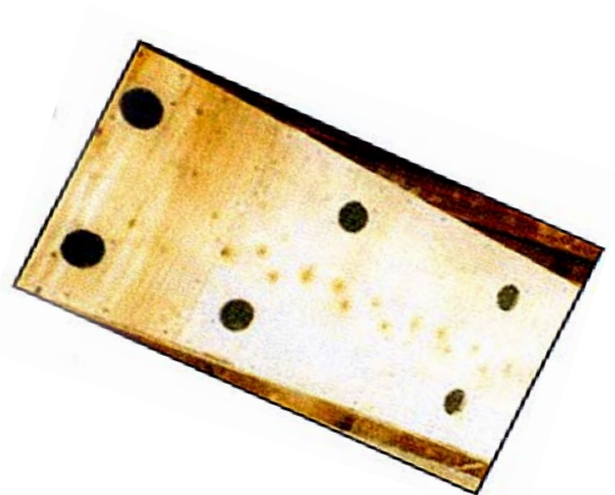

## 6 Use of Standard Plans

The Building and Safety Division Accepts Standard Plans that can be used by homeowners and contractors to do the work shown in the brochure. These plans tell you in detail how to properly perform the strengthening work for your home. Thousands of people have already used them. Be Next! Obtain your copy at <http://quake.abag.ca.gov/fixit/> or [www.lacity.org/ladbs](http://www.lacity.org/ladbs) (11 x 17 Min. size or larger Req.) also available at our public counter in the building division. You will need to hire an engineer or architect when you have special conditions like a stone or brick foundation, poor quality concrete, cripple walls more than four feet in height, or your home is built without a continuous foundation or on a grade steeper than three feet horizontal to one foot vertical.

# Seismic Strengthening



## 1 What are the Benefits of Strengthening my Home?

Strengthened homes are safer to live in and easier to sell and insure. The Northridge Earthquake showed us that strengthened homes stayed on their foundations in the same neighborhoods where un-strengthened homes did not! Some insurance companies will no longer insure a home unless this work is done. Sellers of homes must also disclose to buyers if their home is unbolted.

## 2 How Much Does Seismic Strengthening Cost?

The cost of the work varies. Some homes have cripple walls that need a lot of blocking while other homes do not have cripple walls. Some homes have plenty of access to the work area while other homes have limited access because of heating ducts or small access holes. The cost of the work will increase significantly if you need to replace an unreinforced masonry foundation or have a lot of termite or fungus damage to the wood. You will get an idea of the fair value of the work to be done by getting at least three different bids from contractors.

Most single-family homes on level or near level lots can expect to pay from \$2,000 to \$4,000 for the total job. This price assumes a contractor did the work according to the Standard Plan and there were no special conditions. Homeowners who do the work themselves can help reduce this cost. There will be additional costs if you need to hire an architect or engineer.

## 3 Should I Hire a Contractor?

Most of the work shown on Standard Plans can be done by a homeowner with basic carpentry skills. However, most homeowners are using contractors who specialize in this type of work. What can you afford?

## 4 How do I Find a Contractor?

The best way to find a contractor is through personal references. Be certain the contractor is licensed, insured, finishes the work on time and for the agreed upon price. Do not pay large deposits to start the work. Get a copy of the helpful pamphlet "What You Should Know Before You Hire A Contractor" from the local office of the Contractor's State License Board.

## 5 How Do I Find An Engineer Or Architect?

The following professional associations can recommend experienced members to help you.

Structural Engineers (SEAOSC)

[www.seaosc.org](http://www.seaosc.org)

Phone: (916) 447-1198

Architects (AIA)

[www.aia.org](http://www.aia.org)

Phone: (800) AIA-3837

## Trouble – Free Permits

The City of R P V wants to simplify your home earthquake strengthening project.

Please call us @ (310) 265-7800, or Visit us on line [www.palosverdedds.com/rpv](http://www.palosverdedds.com/rpv)

With any questions you may have.

## 6 Do I Need A Building Permit?

Yes. The Building permit process protects your interests by providing building inspections. Our knowledgeable and well-trained inspectors will check the quality and quantity of the work. This helps you make sure the job is done right.

You will have a permanent record in the Building Division address files that the work was permitted and inspected. You should keep the final inspection card and plans for additional proof.

## 7 How Do I Get a Building Permit?

Getting a building permit is as easy as 1-2-3. First, prepare your plan. Someone will need to crawl under your home to see what details your plan will use. If you use a Standard Plan, complete the foundation outline and reference the details you want to use.

Second, bring your completed plan to the RPV Building Department for review by our helpful and friendly staff. We can answer any questions you have to help you complete your plan.

Third, pay a small fee. The fee, usually less than \$200, will cover our costs to review and approve your plans, inspect the work and keep a permanent record of it.

# Are you prepared for the next earthquake?

Rancho Palos Verdes is located in an active area for earthquakes.

Scientists agree that California has entered a period of increased seismic activity. Since 1989, the state has rocked by four magnitude seven earthquakes, and more are certainly on the way. Locally, the Northridge Earthquake showed us the devastation neighborhoods can suffer when a moderate earthquake strikes in the heart of an urban area.



Earthquakes Centered in the Densely Populated Los Angeles Area will have a much more devastating impact.

Los Angeles is crisscrossed with many known earthquake faults. There is a great potential for seismic activity on several of these known faults such as the Cabrillo Fault joining the Palos Verdes Fault offshore, just outside San Pedro Bay, and continuing northwest through San Pedro and into the communities of the Palos Verdes Peninsula. Many tremors happen along these faults; but most go unnoticed. The next big earthquake along one of these faults may cause damage to weak houses and fragile chimneys throughout the Palos Verdes area.



The City of Rancho Palos Verdes wants to help you make your home Earthquake Survivable.